

## CDL CHEMICAL SANITIZING Door-Type Dish Machine



### SPECIFIER STATEMENT

Specified unit will be NSF rated, Centerline™ by Hobart chemical sanitizing door-type dishwasher. Features recirculating design, two selectable cycles, pumped drain, 18" door opening, .86 gallons per rack, LED temperature and operator display, service diagnostics, detergent, rinse aid and sanitizer pumps. Constructed of stainless steel, rated at 51 racks per hour. 120/60/1 standard voltage.

**1 year parts and labor warranty.**

### MODEL

**CDL** Chemical sanitizing

### STANDARD FEATURES

- + 51 racks per hour
- + .86 gallons of water per rack
- + Chemical sanitizing
- + Recirculating design
- + Top-mounted user interface with digital temperature display
- + 4-sided door
- + 1 standard cycle with optional extended cycle
- + 18" pillarless door opening
- + Snap-in, revolving upper and lower anti-clogging wash & rinse arm; low-profile, single-arm design
- + Removable, 2-part stainless steel scrap screen
- + Soft start
- + Automatic pumped drain
- + Automatic fill
- + Service diagnostics with error notifications
- + Delime notification and cycle
- + Chemical pumps standard
- + Electric tank heat
- + Door actuated start
- + Straight through or corner installation

### OPTIONS & ACCESSORIES (Available at extra cost)

- Chemical sensing indicators (low chemical alert)
- Corner splash kit
- Water hammer arrestor kit
- Pumped drain air gap kit
- Peg rack
- Combination rack
- Flanged feet

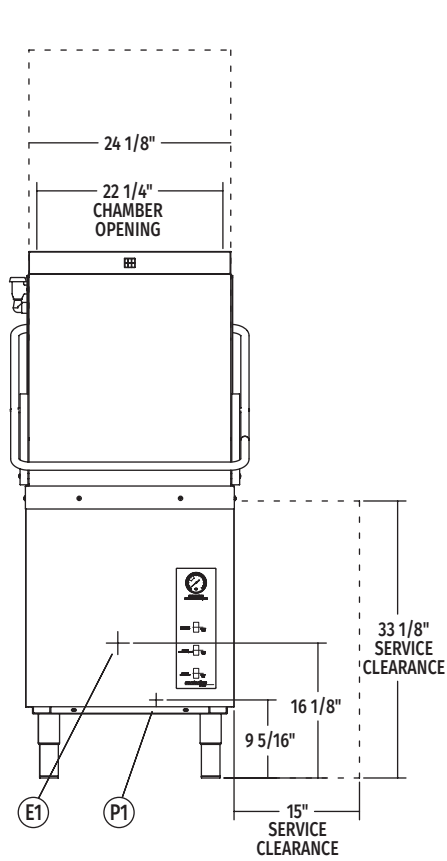

**Front View**

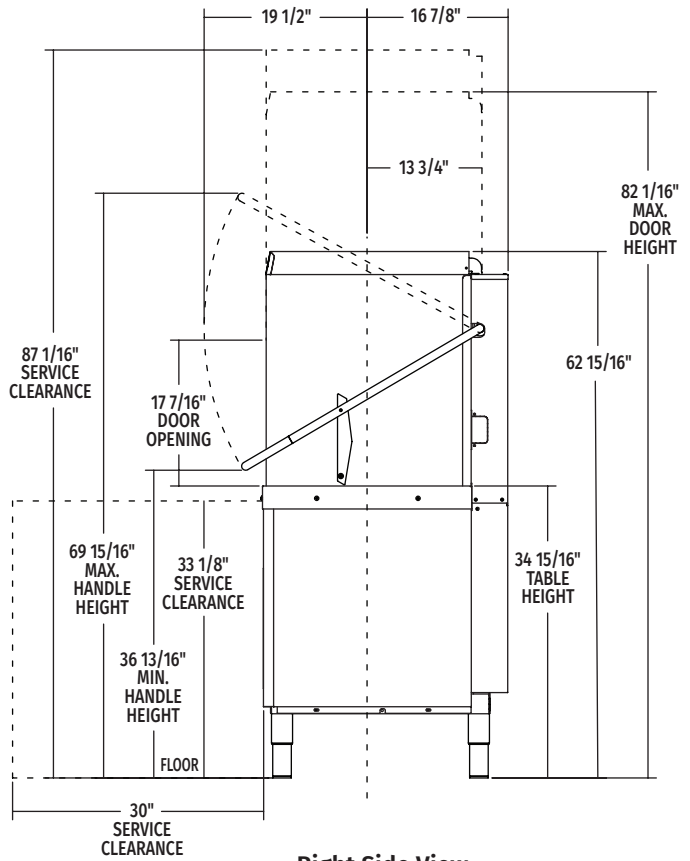

**Right Side View**

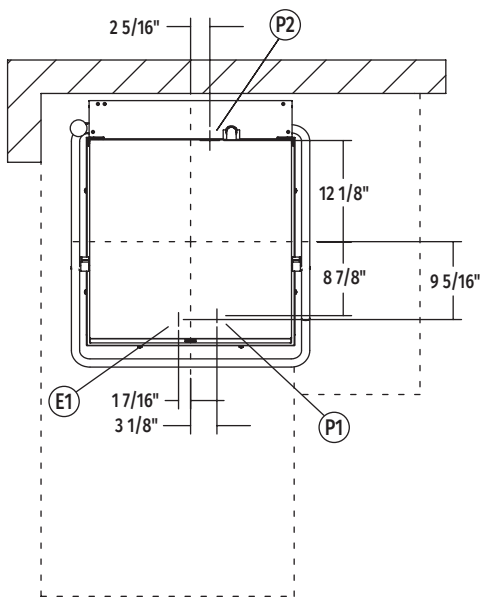

**Top View**

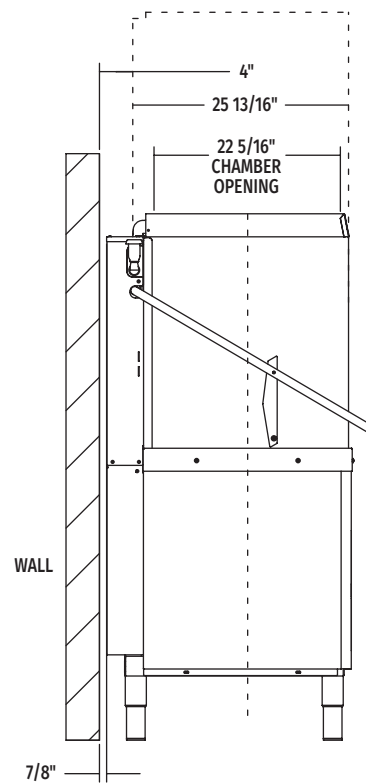

**Left Side View**

**LEGEND**

Electrical Connections	
<b>E1</b>	Electrical connection: 1-1/8" dia. hole for 1" trade size conduit; 8-3/4" AFF.
Plumbing Connections	
<b>P1</b>	Single fill and rinse connection: 3/4" female garden hose fitting on 9' long hose supplied with machine; 120°F water minimum for CDL 140°F recommended.
<b>P2</b>	Drain connection: 19mm barb fitting with 9' long hose supplied with machine.
<b>P3</b>	Chemical supply: Detergent, sanitizer and rinse aid; approximately 8-3/4" AFF. 9' long tubing supplied with machine.

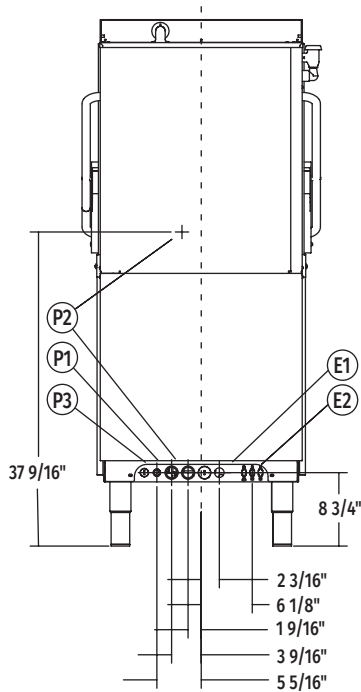

**Back View**

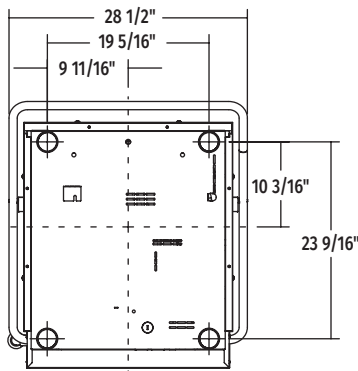

**Bottom View**

**SPECIFICATIONS**

**Capacities**

Racks per Hour (maximum) . . . . .	51
Dishes per Hour (average 25 per rack) . . . . .	1,275
Glasses per Hour (average 45 per rack) . . . . .	2,295
Wash Tank (U.S. gallons) . . . . .	4

**Motor Horsepower**

Wash Pump . . . . .	0.52
Drain Pump . . . . .	0.04

**Rinse**

Gallons per Rack . . . . .	0.86
Gallons per Hour (maximum consumption) . . . . .	43.9

**Peak Rate of Drain Flow**

Gallons per Minute (initial rate with full tank) . . . . .	3.5
--	-----

**Heating**

Electric Heating Unit (kW) . . . . .	2
--------------------------------------	---

**Shipping Weight (approximate)** . . . . . 214 lbs.

**Crated Dimensions** . . . . . 90.0"W x 30.0"L x 33.0"H

CDL Single Point Electrical Service Connection as Shown Below			
Elec. Specs	Rated Amps	Minimum Supply Circuit Ampacity	Maximum Protective Device
120/60/1	17.1	20	20

Approximate Heat Gain to Space without Vent Hood	
Type	BTU/Hr.
Latent	2,300
Sensible	1,000

**WARNING: Electrical and grounding connections must comply with the applicable portion of the National Electrical Code and/or other local electrical codes.**

**Plumbing connections must comply with applicable sanitary, safety, and plumbing codes.**

**Plumbing Notes:**

1. Water hammer arrestor (meeting ASSE-1010 standard or equivalent) to be supplied (by others) in common water supply line at service connection.
2. Recommended water hardness to be 3 grains or less for best results.
3. Recommended building flowing water pressure to the dishwasher is 20-25 PSI. If pressures higher than 25 PSI are present, a pressure regulating valve with internal thermal expansion bypass must be supplied (by others) in the water line to the dishwasher.
4. For convenience when cleaning, water tap should be installed near machine with heavy duty hose and squeeze valve.

**Miscellaneous Notes:**

1. All vertical dimensions taken from floor line may increase or decrease 1-1/4" depending on leg adjustment.
2. Vent hood (if required) to provide a minimum of 450 CFM exhaust (ref installation instructions).
3. Net weight of machine: 199 lbs.  
Domestic shipping weight: 214 lbs.
4. Size of racks – 19¾" x 19¾".

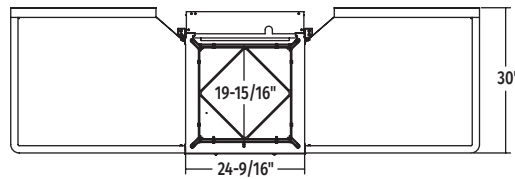

**PASS THRU  
INSTALLATION**

**TOP INSIDE VIEW OF MACHINE**

NOTE: REPOSITION RACK TRACK BRACKET FOR CORNER INSTALLED UNITS

NOTCH FOR HANDLE CLEARANCE:  
5" WIDE x 1-1/2" TALL  
MEASURED FROM TABLE SURFACE

NOTCH FOR HANDLE CLEARANCE:  
5" WIDE x 1-1/2" TALL  
MEASURED FROM TABLE SURFACE

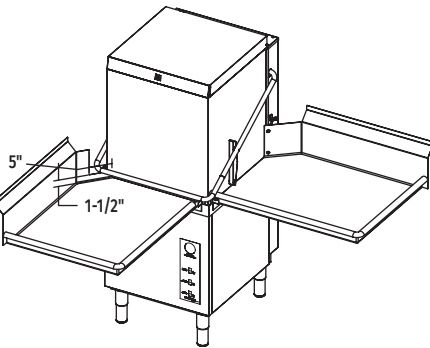

**CORNER  
INSTALLATION**

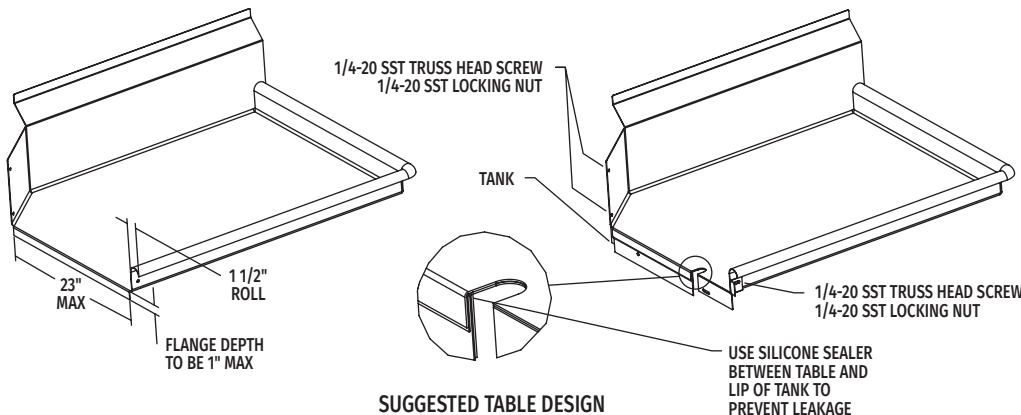
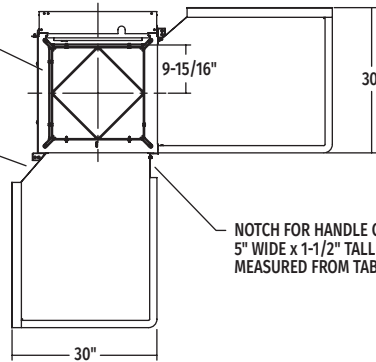

**SUGGESTED TABLE DESIGN**

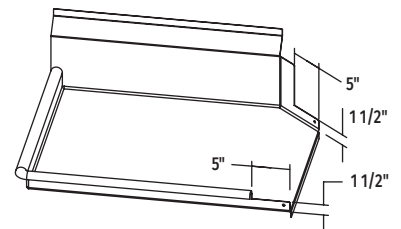

**CORNER TABLE  
CUTOUTS**